

INSTALLATION INSTRUCTIONS

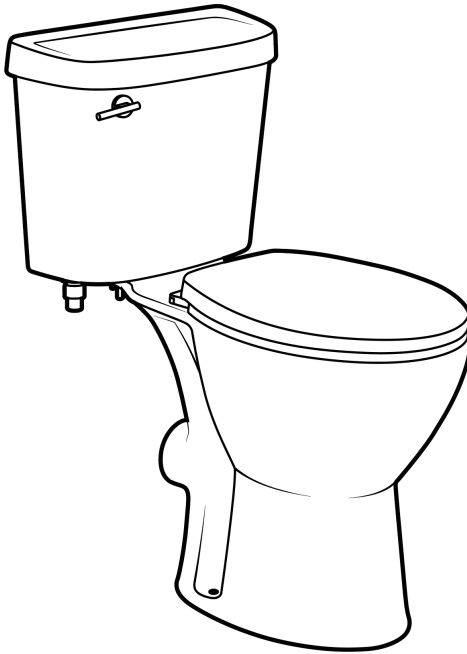

R19 Two Piece Toilet



NOTE: Drawing may not exactly define the contour of the product.

cs@maceratingflo.com www.maceratingflo.com (+1) 626-670-9903



Scan the QR code to read
R19 Macerating Toilet System Online Manual
(MT019T04 Toilet + MF600P01/MF750P01 Macerator Pump)

NOTE:
Keep reading this manual for installing **R19 Toilet** (MT019T04)

TABLE OF CONTENTS:

PRIOR TO INSTALLATION	3
SUGGESTED TOOLS AND MATERIALS	4
PRODUCT DIMENSION	4
PARTS LIST	5
BEFORE INSTALLATION	6
START INSTALLATION	7
TROUBLESHOOTING GUIDE	13
LIMITED WARRANTY COVERAGE	15

PRIOR TO INSTALLATION:

- Inspect toilet to ensure no damages have occurred while in shipping.
- Observe all plumbing and building codes in accordance with your state and local requirements.
- Remove the old toilet.
- Make sure mounting surface is **CLEAN** and **LEVEL**.
- The above drawing is not to scale and is for illustrative purposes only. Please refer to the product dimension or our website: www.maceratingflo.com.
- Two people are recommended to install and move this product.
- **FRAGILE GOODS!** To avoid breakage and possible injury, handle with care

General Recommendations:

Please read the installation instructions thoroughly before installing the toilet.

The step-by-step guidelines in the installation instructions are a general reference for installing a MaceratingFlo Toilet. Should there be any discrepancies, MaceratingFlo cannot be held liable. It is recommended to install all MaceratingFlo Products by hiring a licensed professional.

Be sure to use proper tools and always wear proper personal safety accessories for your protection.

**If you have any questions or concerns
please contact us:**

cs@maceratingflo.com
(+1) 626-670-9903

SUGGESTED TOOLS AND MATERIALS (Not Included)



Wrench

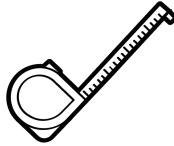

Tape Measure

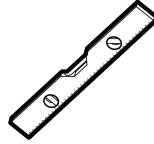

Level

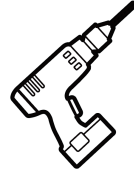

Drill



Cross Head
Screwdriver



Flat Head
Screwdriver



Pencil



Water Supply Kit



Cut Resistant Gloves

PRODUCT DIMENSIONS

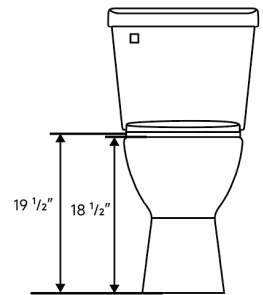
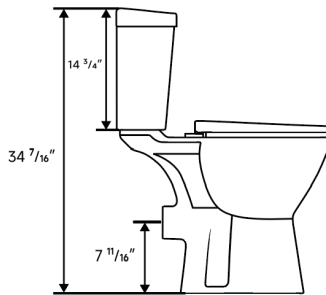
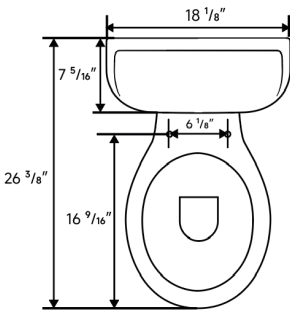

PARTS LIST



MT019T04 Toilet Bowl

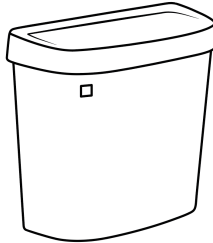

MT019T04 Water Tank
(With Fill Valve & Flapper Kit Pre-installed)

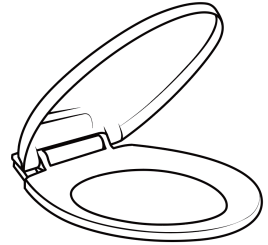

Toilet Seat

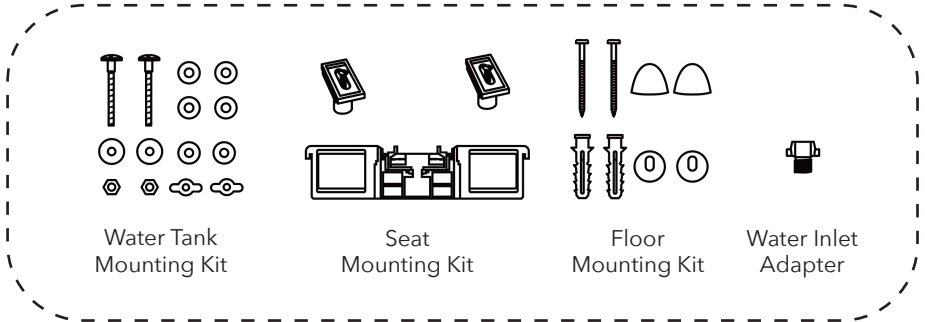

Water Tank
Mounting Kit



Seat
Mounting Kit

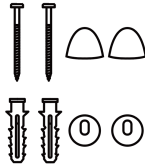

Floor
Mounting Kit



Water Inlet
Adapter

Toilet Installation Accessories



Lever

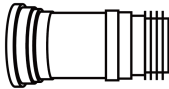

Flexible Extension Pipe

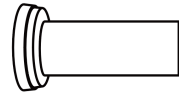

Rigid Extension Pipe

BEFORE INSTALLATION

1. Ensure that your bathroom has a drain exit and the cold water supply in place.
2. To fit your new toilet correctly, please check the following dimensions:
 - ① The distance between the finished floor and the center of the wall drain exit, "Rough-in," must be about 7 inches.
 - ② The PVC-U pipe of the wall drain exit should extend beyond the finished wall by about 0.4-0.5 inches.
 - ③ The water supply should be located approximately 7.9-9.8 inches to the left (when facing the bowl) of the toilet, and approximately 5.9-7.9 inches above the finished floor. (Only applicable for the wall water supply.)
3. Water Supply: As the illustration shows, if your cold water line runs through the wall, install an Angle Stop. If it runs through the floor, install a Straight Stop.

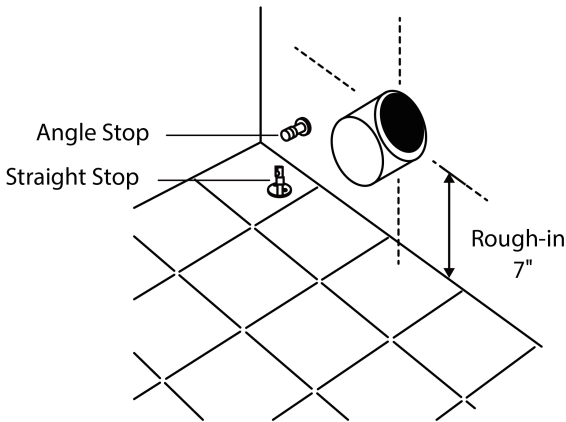

START INSTALLATION

Step 1: Old Toilet Removal (If Applicable)

- **Shut Off Water Supply:** Ensure the water supply valve is fully turned off.
- **Flush And Empty:** Depress the flush handle to drain water from the tank. Then manually remove any remaining water from the tank or bowl using a sponge or towel.
- **Disconnect The Supply Line:** Carefully detach the water supply line connected to the tank.
- **Detach The Toilet:** First, take off any decorative caps on the base of the toilet. Next, unscrew the nuts that fasten the toilet to the floor.
- **Lift Away The Toilet:** With a firm grip, lift the toilet off its base and set it aside or dispose of it according to local regulations.
- **Prepare For New Installation:** Remove the old toilet bolts from the toilet flange. Clean the base area thoroughly ensuring any residues like old wax or putty are removed.

Step 2: Measure And Label The Measurement

- Align the toilet's drain exit with the wall drain exit and place the toilet bowl on the ground.
- And record the following measurement:
 - ① Center distance from the ground.
 - ② Distance of the outlet from the wall.
 - ③ Diameter of the outlet.
 - ④ Distance of the mounting hole from the wall.

NOTE: If the toilet's drain exit cannot be connected to the wall drain exit, please use an "Extension Pipe", and ensure that there is no leakage at the junction. You can also cut the "Extension Pipe" as needed.

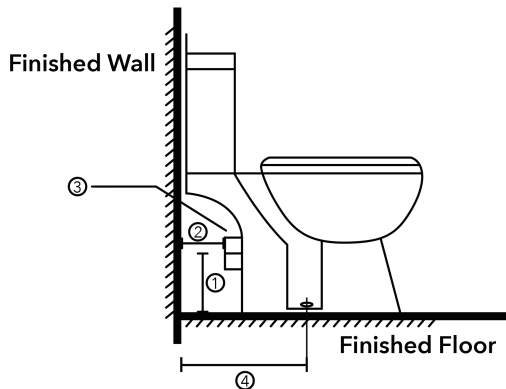

Step 3: Determine The Toilet Installation Location

- Place the toilet at the designated spot.
- Mark the points at the mounting holes, then remove the toilet.
- Drill the mounting holes at the marked points, then put the toilet in place.

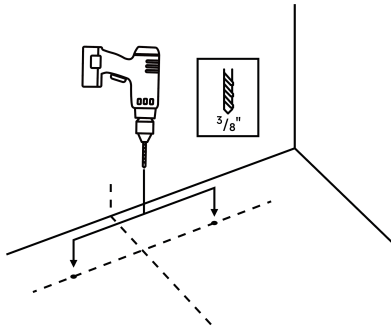

Step 4: Connect And Mount The Toilet

- Connect the toilet to the drain outlet or the macerator pump.
- Insert the components to mount the toilet as illustrated. Use a wrench to tighten if needed. (Do not overtighten.)

NOTE: Position the macerator pump at the intended spot before mounting the toilet if needed.

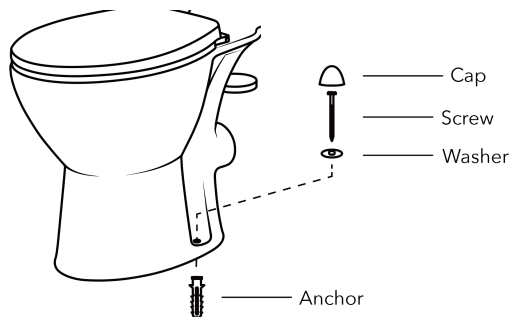

Step 5: Water Tank Assembly

- Position the tank-to-bowl gasket over the tank nut, ensuring there is no gap between the gasket and the tank.
- Insert the two tank bolts into the tank mounting holes. Lift the tank and guide the bolts to align the tank with the bowl.
- Place the washers and nuts as illustrated. Alternately tighten the nuts to secure the tank to the toilet bowl.

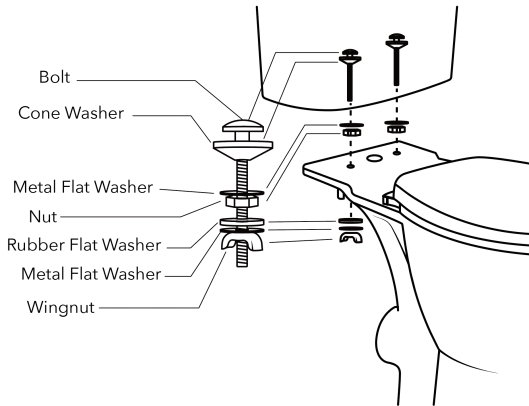

Step 6: Install Flush Lever

• Lever Assembly

1. Unscrew the positioning rubber, rubber washer, and plastic nut from the lever arm by turning it clockwise.
2. Insert the lever arm and the positioning rubber through the square hole on the tank's front side.
3. Adjust the rubber until it fits perfectly.
4. Secure the lever arm by tightening the rubber washer and plastic nut counterclockwise.

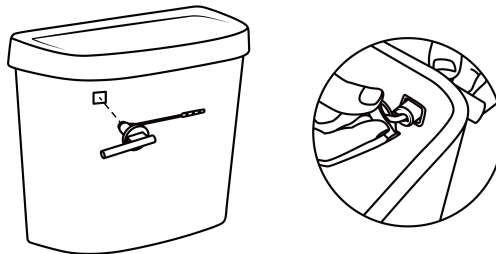

• Attach Flapper

1. Attach the chain from the flapper to the lever arm.
2. Ensure the chain length allows the flapper to fully raise when the lever is activated. Keep 5 or 6 extra chain links for potential future adjustments.

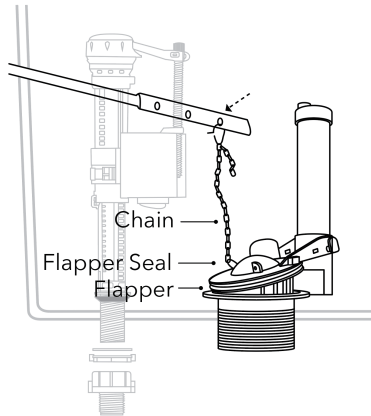
**Step 7: Install The Water Supply Pipe And Test Flushing**

- Connect the toilet water supply line. We offer a $\frac{7}{8}$ " to $\frac{1}{2}$ " fill valve pipe adapter. Use the adapter if needed.
- Tighten the supply line securely and turn on the water supply.

NOTE: Avoid using plumber's putty, pipe dope, or any other sealants on the water supply connection to this tank. If a leak occurs after hand-tightening, consider replacing the supply line. If the leakage persists with a new supply line, it may be necessary to replace the fill valve.

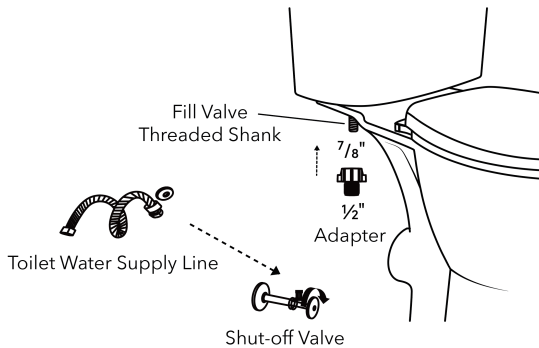

- Conduct a flushing test on the toilet, ensuring everything flows correctly. And activate the pump as intended, if used.
- After the flushing test, check all connection points for potential leaks. Tighten any loose connections further if issues persist.

Step 8: Install The Toilet Seat

- Insert the expansion bolts into the bracket.

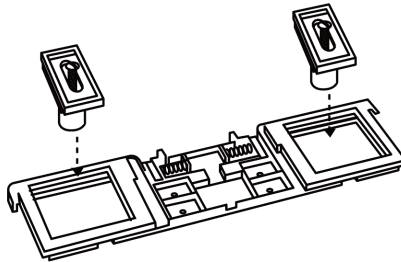

- Then insert them into the hole of the toilet bowl and adjust the position of the bracket correctly. (The spring side rests on top.)
- Tighten the expansion bolts with the cross screwdriver.

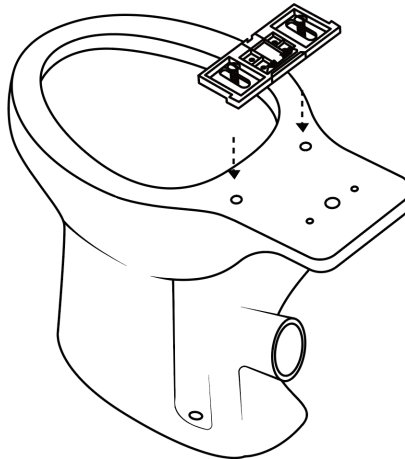

- Place the toilet seat horizontally into the bracket.
- Finally, adjust the position of the toilet seat to align it with the bowl.

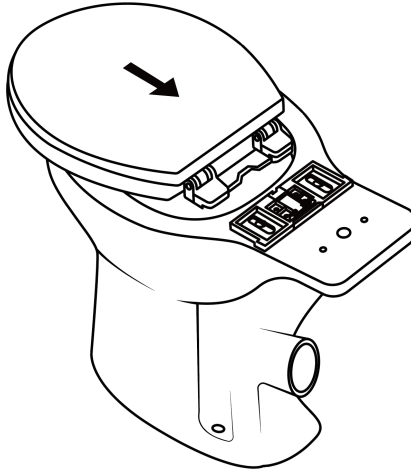

TROUBLESHOOTING GUIDE



When servicing or replacing any components, be sure the water supply is shut off and the toilet is flushed.

SYMPTOMS	PROBABLE CAUSES	REMEDIES
Does not flush	<ul style="list-style-type: none"> • Water supply valve closed. • Supply line blocked. • Flush valve chain too loose or disconnected. 	<ul style="list-style-type: none"> • Open valve and allow water to fill tank. • Shut off water supply, disconnect supply line and inspect its accessories. Reassemble. • Readjust chain length as required.
Poor flush	<ul style="list-style-type: none"> • Supply valve partly closed. 	<ul style="list-style-type: none"> • Open supply valve fully. Be sure that proper supply tube size is used.
	<ul style="list-style-type: none"> • Partially clogged trapway and/or drain pipe and/or vent. 	<ul style="list-style-type: none"> • Remove obstruction. Consult a plumber if necessary.
	<ul style="list-style-type: none"> • Low water level in the tank. 	<ul style="list-style-type: none"> • Adjust the fill valve to raise water level in tank. (Review Figure 1)
	<ul style="list-style-type: none"> • Flush volume too low. 	<ul style="list-style-type: none"> • Adjust the position of the chain hook on the chain. • Detach the chain hook from the lever, reposition it on the chain, and then reattach the hook to the correct hole on the flush lever.
Toilet leaks	<ul style="list-style-type: none"> • Supply pressure too low. 	<ul style="list-style-type: none"> • Normal supply pressure must be at least 35 PSI.
	<ul style="list-style-type: none"> • Poor supply line connection. • Poor bowl to tank/wall connection. 	<ul style="list-style-type: none"> • Review Step 7 of installation procedure. • Review Step 2 through 5 of installation procedure.
Toilet does not shut off	<ul style="list-style-type: none"> • Flapper seal leaking or deformed. 	<ul style="list-style-type: none"> • Clean debris from seal surface. Replace flapper seal as needed.

- ① Unlock the clip
- ② Adjust the lever float upward
- ③ Level the float with the lever float

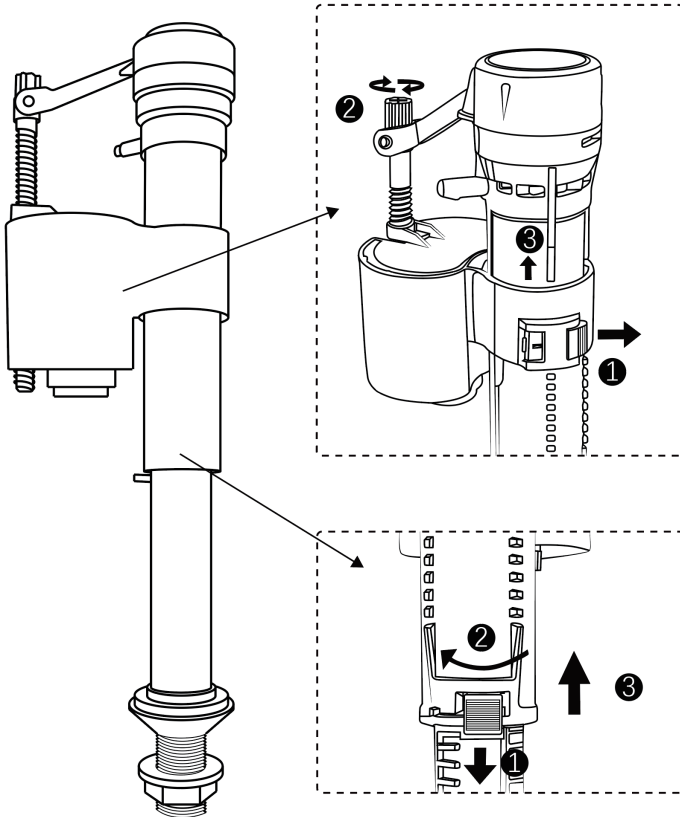

- ① Unlock the clip
- ② Twist the valve
- ③ Adjust the height

(Note: Do not exceed the internal tank height.)

TIP: Please remember to restore the clips after adjustment.

Figure 1

LIMITED WARRANTY COVERAGE

TWO YEAR LIMITED WARRANTY

MaceratingFlo products are crafted with superior materials and impeccable workmanship, offering our customers reliable and long-lasting products. If defects in materials or craftsmanship are detected under standard use within the first two years of installation, MaceratingFlo will either supply replacement parts at no charge or, if deemed necessary, replace the product or its parts, this warranty is exclusive to the original purchaser, and proof of purchase is mandatory for any claim.

We strongly advise all MaceratingFlo product installations be handled by a licensed, professional plumber or contractor. MaceratingFlo won't be held liable for damages or product malfunctions due to incorrect installation, misuse, or if a licensed professional isn't employed for the installation. We won't cover any associated installation or removal expenses.

This Warranty Will Be Voided If:

- The product's installation did not follow our recommendations.
- The product was relocated from its initial installation site.
- The product underwent any modifications from its original condition.
- The product suffered from neglect, misuse, chemical overuse, accidents, or any other damages.

MaceratingFlo does not imply that our products adhere to local building or plumbing codes. Consumers must ascertain local code compliance before and during installation. This warranty is strictly for the original purchaser and first consumer.

MaceratingFlo won't be held responsible for any consequential damages linked to the product's installation, replacement, return, or usage. This includes, but is not limited to, freight charges, labor, downtime, home damages, and other associated costs (e.g., professional services, investigations, audits, legal fees).

This MaceratingFlo warranty clearly delineates our liability. Items not specified in this warranty fall outside MaceratingFlo's responsibility. In states with variations concerning implied warranties, our compliance is ensured.

For any queries or concerns, feel free to reach out to us at

Email: cs@maceratingflo.com
Phone: (+1) 626-670-9903
Site: www.maceratingflo.com